

AQUAPACER w/RAMPS, 1025GAL TANK (SYSTEM SAMPLE LAYOUT)

CONSTRUCTION TO BE DONE BY FACILITY:

- ⚠ - 64" WIDE x 88" HIGH MIN DOOR OPENING WITH 165" MIN SWING CLEARANCE
- ALL APPROVALS, PERMITS, AND AGENCY SUBMITTALS
- WET ENVIRONMENT, DESIGN ROOM ACCORDINGLY
- ROOM MUST REMAIN ABOVE FREEZING AT ALL TIMES OR WARRANTY IS VOIDED
- NEED FORKLIFT WITH FORKS 7-3/4" WIDE (MAX) x 6FT LONG (MINIMUM)
- FLOOR UNDER TREADMILL BE FLAT & LEVEL WITHIN .5" PER 12FT

PLUMBING TO BE DONE BY FACILITY:

- ⚠ - 4" FLOOR DRAIN NEAR TREADMILL CORNER AND WATER STORAGE TANK
- ⚠ - ADDITION DRAIN MAY BE ADDED TO HANDLE RAPIDLY DUMPED WATER
- COLD WATER SUPPLY WITH HOSE BIB, FOR FILLING WATER STORAGE TANK
- HOT WATER WITH HOSE BIB FOR MAKEUP, TREADMILL & CARTRIDGE CLEANING

ELECTRICAL TO BE DONE BY FACILITY:

- ⚡ - 230V | 1PH | 60HZ | 50AMP | 3 WIRE ELECTRICAL SUPPLY AND MOUNT DISCONNECT
- CONNECT INCOMING POWER TO CONTROL PANEL PER NEC CODE
- EQUIPMENT WILL RUN BELOW 230VAC, BUT SHORTENS LIFE EXPECTANCY AND VOIDS WARRANTY (AN AQUABOOST TRANSFORMER P/N0789490 RAISES 20VAC)

HUDSON SUPPLIED:

- CUSTOM DESIGNED LAYOUT DRAWING WITH THE PURCHASE OF PRODUCT
- INSTALLATION OF PURCHASED ITEMS AS PER FINAL SIGNED DRAWING
- ON SITE IN-SERVICE TRAINING PROVIDED AFTER INSTALL
- "ASK SAM" WATER CARE SERVICE & AFTER HOURS SERVICE SUPPORT
- PROPOSED PLUMBING PATH FOR GRAVITY DRAINING OF UNITS

PURCHASED SYSTEM:

0790557
 AQUAPACER
 1025 GALLON TANK w/RECIRC.
 ENTRY RAMPS

FACILITY LAUOUT:

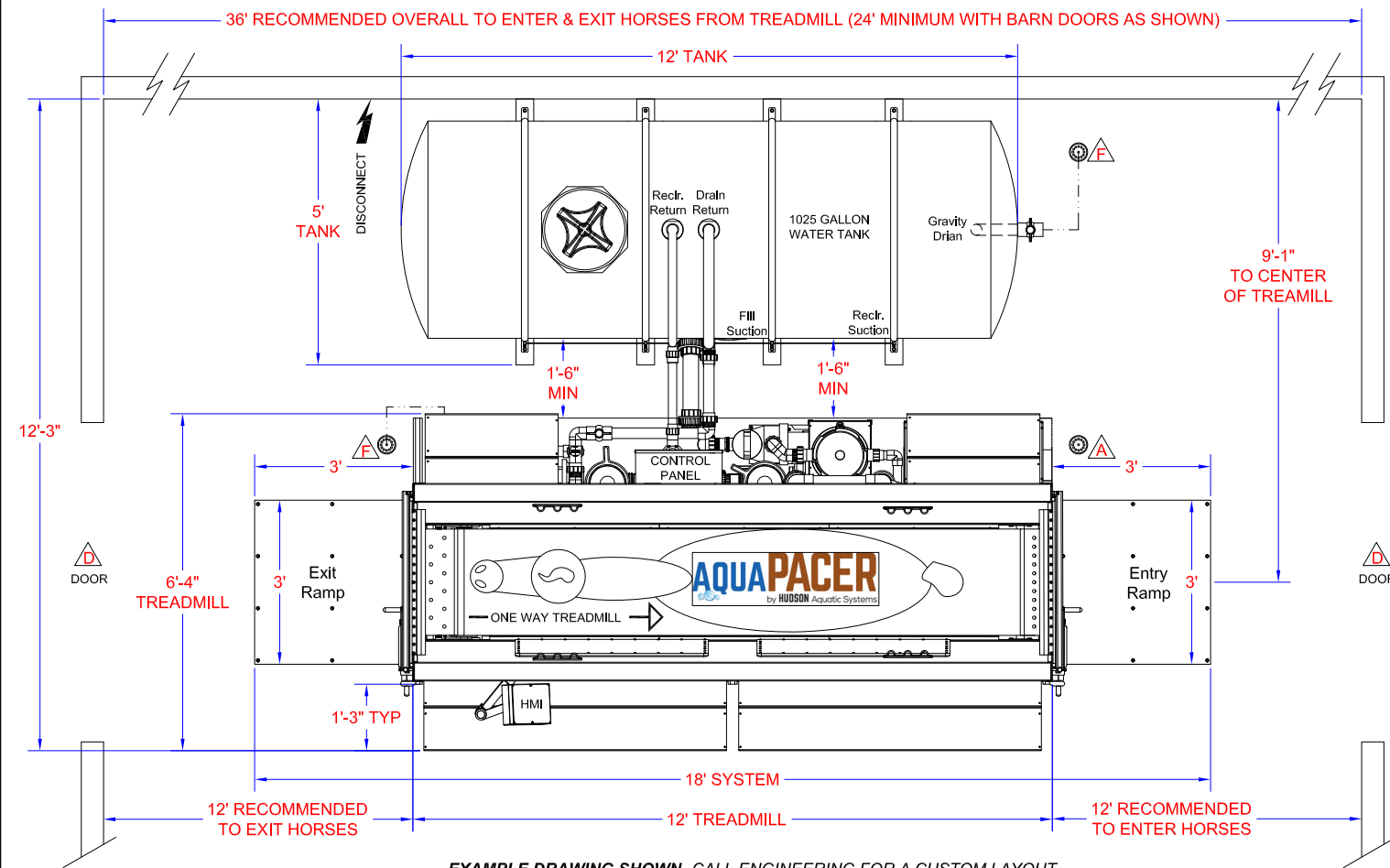

ELEVATION VIEW:

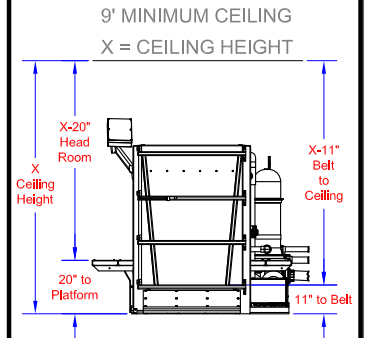

NOTE: CHECK HEAD CLEARANCES FOR HORSES AND HUMANS

WEIGHTS:

- TREADMILL EMPTY: 4,500 LBS
- TREADMILL w/43" WATER: 13,000 LBS
- 1025 GALLON TANK EMPTY: 530 LBS
- 1025 GALLON TANK w/WATER: 8,866 LBS

FLOOR LOAD:

- TREADMILL w/43" WATER: 217 LBS PER SQ. FT.
- 1025 GALLON TANK w/WATER: 246 LBS PER SQ. FT.

--- FINAL DRAWING SIGN OFF ---
 PRODUCT TO BE BUILT AND INSTALLED AS SHOWN:

APPROVED BY: _____
 DATE: _____

HUDSON
 AQUATIC SYSTEMS, LLC
 1100 WOHLERT ST | ANGOLA, IN 46703
 PHONE: 1-800-939-3374 | ENG EXT: 222

THIS DRAWING AND INFORMATION CONTAINED THEREON ARE CONFIDENTIAL AND THE PROPERTY OF HUDSON AQUATIC SYSTEMS, LLC. THEY ARE NOT TO BE REPRODUCED, DISTRIBUTED, DISCLOSED OR USED FOR ANY PURPOSE WITHOUT THE EXPRESS WRITTEN CONSENT OF HUDSON AQUATIC SYSTEMS.

| | | | | |
|------------------|--------------------------|------------------------|-----------------------|--|
| DRAWN BY: SDS | SALESMAN: XXXXX XXXXX | REV. DATE: 11-16-22 | DRAWING #: XX-XXXX | FACILITY NAME: AQUAPACER w/RAMPS, 1025GAL TANK (SYSTEM SAMPLE LAYOUT) |
|------------------|--------------------------|------------------------|-----------------------|--|

AQUAPACER w/RAMPS, 1000GAL TANK (SYSTEM SAMPLE LAYOUT)

CONSTRUCTION TO BE DONE BY FACILITY:

- ⚠ - 64" WIDE x 88" HIGH MIN DOOR OPENING WITH 165" MIN SWING CLEARANCE
- ALL APPROVALS, PERMITS, AND AGENCY SUBMITTALS
- WET ENVIRONMENT, DESIGN ROOM ACCORDINGLY
- ROOM MUST REMAIN ABOVE FREEZING AT ALL TIMES OR WARRANTY IS VOIDED
- NEED FORKLIFT WITH FORKS 7-3/4" WIDE (MAX) x 6FT LONG (MINIMUM)
- FLOOR UNDER TREADMILL BE FLAT & LEVEL WITHIN .5" PER 12FT

ELECTRICAL TO BE DONE BY FACILITY:

- ⚡ - 230V | 1PH | 60HZ | 50AMP | 3 WIRE ELECTRICAL SUPPLY AND MOUNT DISCONNECT
- CONNECT INCOMING POWER TO CONTROL PANEL PER NEC CODE
- EQUIPMENT WILL RUN BELOW 230VAC, BUT SHORTENS LIFE EXPECTANCY AND VOIDS WARRANTY (AN AQUABOOST TRANSFORMER P/N0789490 RAISES 20VAC)

HUDSON SUPPLIED:

- CUSTOM DESIGNED LAYOUT DRAWING WITH THE PURCHASE OF PRODUCT
- INSTALLATION OF PURCHASED ITEMS AS PER FINAL SIGNED DRAWING
- ON SITE IN-SERVICE TRAINING PROVIDED AFTER INSTALL
- "ASK SAM" WATER CARE SERVICE & AFTER HOURS SERVICE SUPPORT
- PROPOSED PLUMBING PATH FOR GRAVITY DRAINING OF UNITS

PURCHASED SYSTEM:

0790557 OPT2
 AQUAPACER
 1000 GALLON TANK w/RECIRC.
 ENTRY RAMPS

PLUMBING TO BE DONE BY FACILITY:

- ⚠ - 4" FLOOR DRAIN NEAR TREADMILL CORNER AND WATER STORAGE TANK
- ⚠ - ADDITION DRAIN MAY BE ADDED TO HANDLE RAPIDLY DUMPED WATER
- COLD WATER SUPPLY WITH HOSE BIB, FOR FILLING WATER STORAGE TANK
- HOT WATER WITH HOSE BIB FOR MAKEUP, TREADMILL & CARTRIDGE CLEANING

FACILITY LAUOUT:

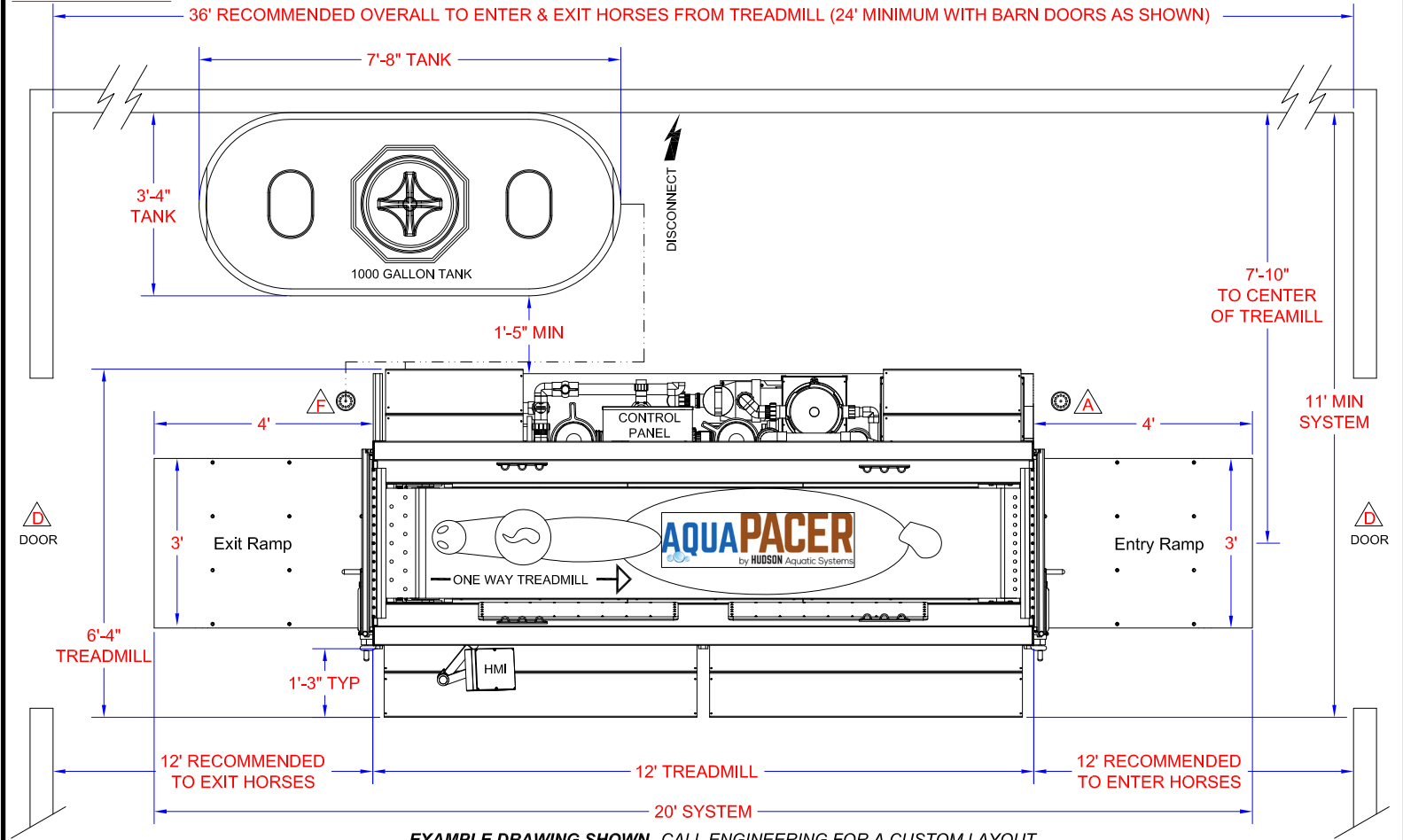

--- EXAMPLE DRAWING SHOWN, CALL ENGINEERING FOR A CUSTOM LAYOUT ---

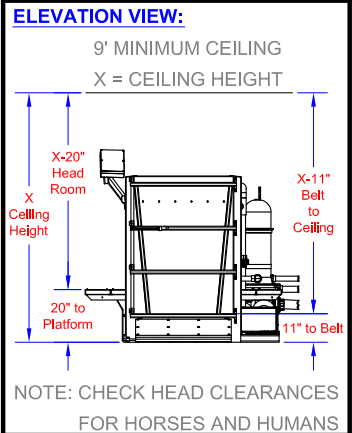

WEIGHTS:

| | |
|------------------------------|------------|
| TREADMILL EMPTY | 4,500 LBS |
| TREADMILL w/43" WATER WEIGHT | 13,000 LBS |
| 1000 GALLON TANK EMPTY | 430 LBS |
| 1000 GALLON TANK w/WATER | 8,766 LBS |

FLOOR LOAD:

| | |
|------------------------------|---------------------|
| TREADMILL w/43" WATER WEIGHT | 217 LBS PER SQ. FT. |
| 1000 GALLON TANK w/WATER | 458 LBS PER SQ. FT. |

HUDSON
 AQUATIC SYSTEMS, LLC
 1100 WOHLERT ST | ANGOLA, IN 46703
 PHONE: 1-800-939-3374 | ENG EXT: 222

THIS DRAWING AND INFORMATION CONTAINED THEREON ARE CONFIDENTIAL AND THE PROPERTY OF HUDSON AQUATIC SYSTEMS, LLC. THEY ARE NOT TO BE REPRODUCED, DISTRIBUTED, DISCLOSED OR USED FOR ANY PURPOSE WITHOUT THE EXPRESS WRITTEN CONSENT OF HUDSON AQUATIC SYSTEMS.

| | | | | |
|---------------|-----------------------|---------------------|--------------------|---|
| DRAWN BY: SDS | SALESMAN: XXXXX XXXXX | REV. DATE: 11-16-22 | DRAWING #: XX-XXXX | FACILITY NAME: AQUAPACER w/RAMPS, 1000GAL TANK (SYSTEM SAMPLE LAYOUT) |
|---------------|-----------------------|---------------------|--------------------|---|

--- FINAL DRAWING SIGN OFF ---
 PRODUCT TO BE BUILT AND INSTALLED AS SHOWN:
 APPROVED BY: _____
 DATE: _____