

CONSTRUCTION TO BE DONE BY FACILITY:

- 34-5/8" MINIMUM OPENING WITH 84" MINIMUM HALLWAY SWING CLEARANCE
- MAKE SURE THE ELECTRICAL WALL RECEPTACLE AND DISCONNECT IS WITHIN 10FT OF THE PROPOSED CONTROL PANEL LOCATION SHOWN ON DRAWING.
- 9' MINIMUM CEILING REQUIRED ABOVE WATER TANK ONLY
- ALL APPROVALS, PERMITS, AND AGENCY SUBMITTALS
- WET ENVIRONMENT, DESIGN ROOM ACCORDINGLY, VENT 50CFM MINIMUM

PLUMBING TO BE DONE BY FACILITY:

- 3" FLOOR DRAIN NEAR TREADMILL EQUIPMENT - REQUIRED
- 3" FLOOR DRAIN NEAR TREADMILL ENTRY - RECOMMENDED
- COLD WATER SUPPLY WITH HOSE BIB, FOR FILLING WATER STORAGE TANK
- HOT WATER WITH HOSE BIB FOR MAKEUP, TREADMILL & CARTRIDGE CLEANING

FACILITY LAYOUT:

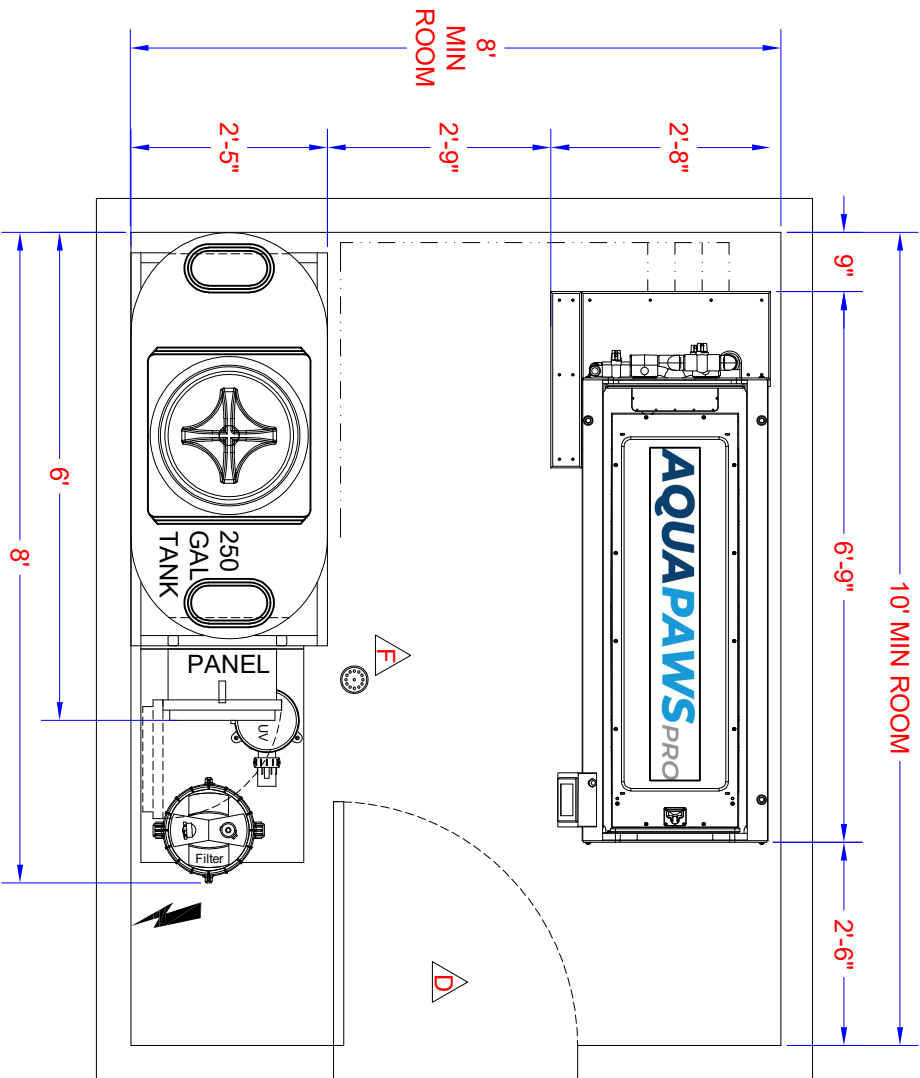

ELECTRICAL TO BE DONE BY FACILITY:

- 230V | 1PH | 60HZ | LEVITON 279, 50AMP | NEMA 14-50R, 3 POLE, 4 WIRE (WALL PLUG RECEPTACLE MUST BE WITHIN 10FT OF CONTROL PANEL)
 - FLUSH MOUNTING RECEPTACLE, STRAIGHT BLADE, INDUSTRIAL GRADE, GROUNDING, SIDE WIRED, STEEL STRAP, BLACK IS IN PLACE (MUST USE ALL 4 WIRES). CONNECT TO DESIGNATED CIRCUIT A SIEMENS GFI 50-AMP SPA PANEL, **MODEL # W0408L1125SPAS0 (REQUIRED)** WITHIN 10FT OF PANEL
 - EQUIPMENT WILL RUN BELOW 230VAC, BUT SHORTENS LIFE EXPECTANCY AND VOIDS WARRANTY (AN AQUABOOST TRANSFORMER P/N0789490 RAISES 20VAC)
- HUDSON SUPPLIED:**
- CUSTOM DESIGNED LAYOUT DRAWING WITH THE PURCHASE OF PRODUCT
 - PROPOSED PLUMBING PATH FROM TREADMILL TO EQUIPMENT
 - DOES **NOT INCLUDE** INSTALLATION OR ON SITE IN-SERVICE, BUT (OPTIONAL)
 - "ASK SAM" WATER CARE SERVICE & AFTER HOURS SERVICE SUPPORT

PURCHASED ITEMS:

- 0790102 AQUAPAWS JR
- 250 GALLON TANK w/RECIRC.
- 250 GALLON TANK STAND
- 0790950-JR UV WATER SANITIZER
- 0790104-A 4 PACK JETS

--- EXAMPLE DRAWING SHOWN, CALL ENGINEERING FOR A CUSTOM LAYOUT ---

THIS DRAWING AND INFORMATION CONTAINED THEREON ARE CONFIDENTIAL AND THE PROPERTY OF HUDSON AQUATIC SYSTEMS, LLC. THEY ARE NOT TO BE REPRODUCED, DISTRIBUTED, DISCLOSED OR USED FOR ANY PURPOSE WITHOUT THE EXPRESS WRITTEN CONSENT OF HUDSON AQUATIC SYSTEMS.

| | | | | |
|------------------|--------------------------|----------------------|-----------------------|---|
| DRAWN BY: HJS | SALESMAN: XXXXX XXXXX | REV. DATE: 4-2-24 | DRAWING #: XX-XXXX | FACILITY NAME: AQUAPAWS PRO SAMPLE (PARALLEL) LAYOUT DRAWING |
|------------------|--------------------------|----------------------|-----------------------|---|

100 WOHLETT ST | ANGOLA, IN 46703
HOME:1-800-939-5374 | ENG EXT: 222



WEIGHTS:

- TREADMILL EMPTY 780 LBS
- TREADMILL w/27" WATER 2,920 LBS
- 250 GAL TANK & PUMPS EMPTY 600 LBS
- 250 GAL TANK & PUMPS w/WATER 2,684 LBS

FLOOR LOADS:

- TREADMILL w/27" WATER 258 LBS PER SQ. FT.
- 250 GAL TANK & PUMPS w/WATER 171 LBS PER SQ. FT.

--- FINAL DRAWING SIGN OFF ---
PRODUCT TO BE BUILT AND INSTALLED AS SHOWN:

APPROVED BY: _____
DATE: _____