

CONSTRUCTION TO BE DONE BY FACILITY:

- 64" WIDE x 88" HIGH MIN DOOR OPENING WITH 165" MIN SWING CLEARANCE
- ALL APPROVALS, PERMITS, AND AGENCY SUBMITTALS
- WET ENVIRONMENT, DESIGN ROOM ACCORDINGLY
- ROOM MUST REMAIN ABOVE FREEZING AT ALL TIMES OR WARRANTY IS VOIDED
- NEED FORKLIFT WITH FORKS 7.3/4" WIDE (MAX) x 6FT LONG (MINIMUM)
- FLOOR UNDER TREADMILL BE FLAT & LEVEL WITHIN .5" PER 12FT

PLUMBING TO BE DONE BY FACILITY:

- .4" FLOOR DRAIN NEAR TREADMILL CORNER AND WATER STORAGE TANK
- ADDITION DRAINS MAY BE ADDED TO HANDLE RAPIDLY DUMPED WATER
- COLD WATER SUPPLY WITH HOSE BIB, FOR FILLING WATER STORAGE TANK
- HOT WATER WITH HOSE BIB FOR MAKEUP, TREADMILL & CARTRIDGE CLEANING

FACILITY LAUOUT:

36' RECOMMENDED OVERALL TO ENTER & EXIT HORSES FROM TREADMILL (24' MINIMUM WITH BARN DOORS AS SHOWN) 7'-8" TANK

ELECTRICAL TO BE DONE BY FACILITY:

- 230V | 1PH | 60HZ | 50AMP | 3 WIRE ELECTRICAL SUPPLY AND MOUNT DISCONNECT
 - CONNECT INCOMING POWER TO CONTROL PANEL PER NEC CODE
 - EQUIPMENT WILL RUN BELOW 230VAC, BUT SHORTENS LIFE EXPECTANCY AND VOIDS WARRANTY (AN AQUABOOST TRANSFORMER P/N0789490 RAISES 20VAC)
- HUDSON SUPPLIED:**
- CUSTOM DESIGNED LAYOUT DRAWING WITH THE PURCHASE OF PRODUCT
 - INSTALLATION OF PURCHASED ITEMS AS PER FINAL SIGNED DRAWING
 - ON SITE IN-SERVICE TRAINING PROVIDED AFTER INSTALL
 - *ASK SAW* WATER CARE SERVICE & AFTER HOURS SERVICE SUPPORT
 - PROPOSED PLUMBING PATH FOR GRAVITY DRAINING OF UNITS

PURCHASED ITEMS:

- 0790957 OPT2
- AQUAPACER PLUS
- 1000 GALLON TANK w/RECIRC.
- ENTRY RAMPS

OPTIONS - NOT INCLUDED:

- 2182851
- 60AMP MAX SIEMENS DISCONNECT
- 0790364-A
- OZONE WATER SANITIZER
- 0790481
- 420 SQ FT DRAIN PREFILTER
- 0790007
- WATER TANK AUTO FILL VALVE
- 2810405
- INSULATED 1000 GAL TANK COVER

ELEVATION VIEW:

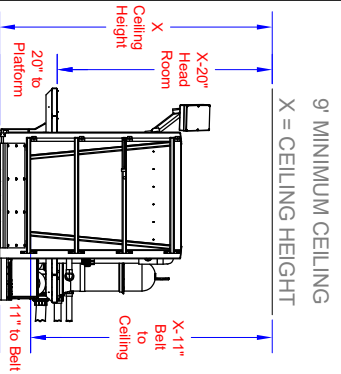

NOTE: CHECK HEAD CLEARANCES FOR HORSES AND HUMANS

WEIGHTS:

- TREADMILL EMPTY 4,500 LBS
 - TREADMILL w/43" WATER 13,000 LBS
 - 1000 GALLON TANK EMPTY 430 LBS
 - 1000 GALLON TANK w/WATER 8,766 LBS
- FLOOR LOAD:**
- TREADMILL w/43" WATER 217 LBS PER SQ. FT.
 - 1000 GALLON TANK w/WATER 458 LBS PER SQ. FT.

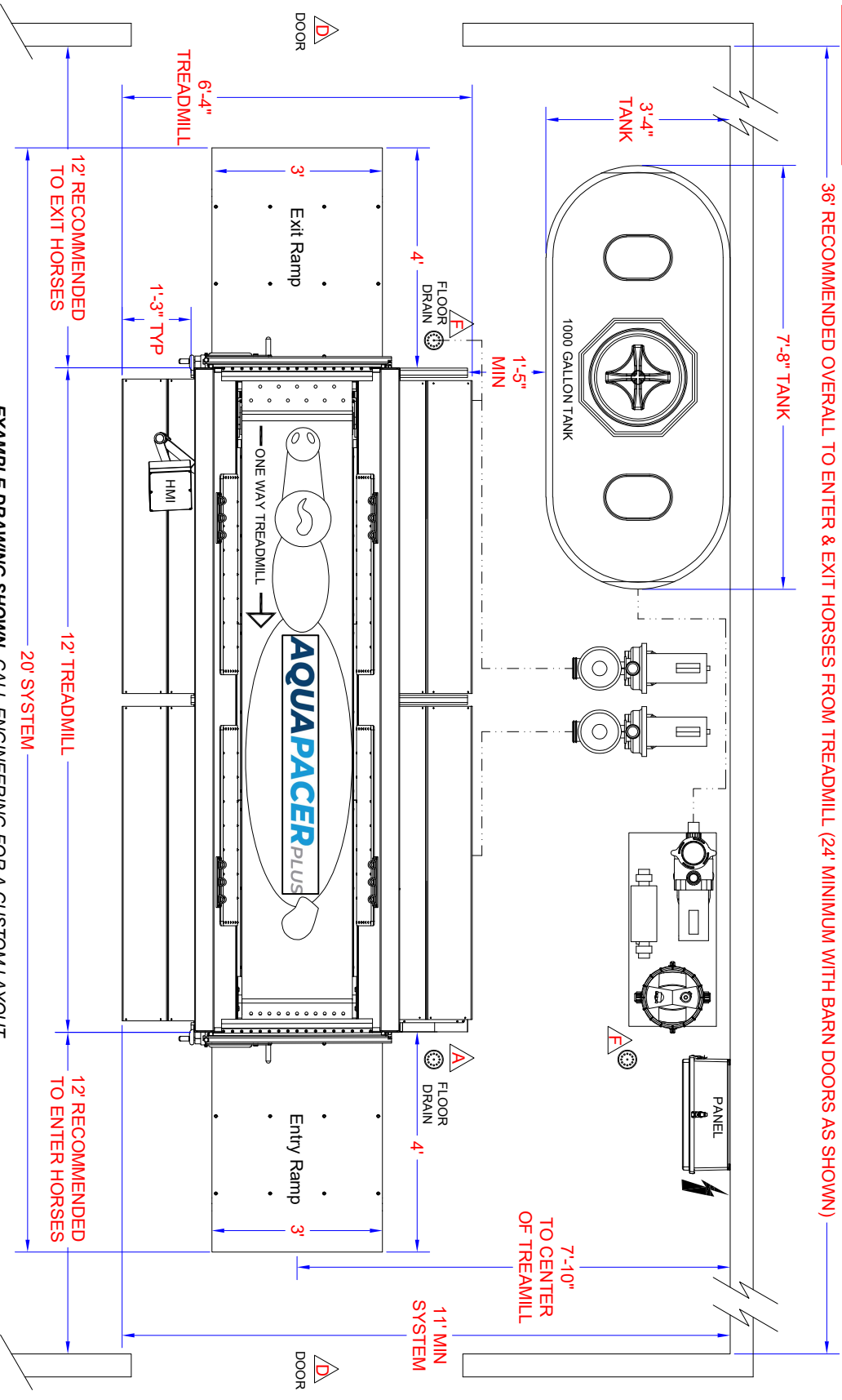

--- EXAMPLE DRAWING SHOWN, CALL ENGINEERING FOR A CUSTOM LAYOUT ---



THIS DRAWING AND INFORMATION CONTAINED THEREON ARE CONFIDENTIAL AND THE PROPERTY OF HUDSON AQUATIC SYSTEMS, LLC. THEY ARE NOT TO BE REPRODUCED, DISTRIBUTED, DISCLOSED OR USED FOR ANY PURPOSE WITHOUT THE EXPRESS WRITTEN CONSENT OF HUDSON AQUATIC SYSTEMS.

100 WOHLETT ST ANCOCLA, IN 46703 HOME:1-800-939-3374 ENG EXT: 222	DRAWN BY: HJS	SALESMAN: XXXXX XXXXX	REV. DATE: 4-2-24	DRAWING #: XX-XXXX	FACILITY NAME: AQUAPACER PLUS (w/1000 GALLON TANK) SAMPLE LAYOUT DRAWING
--	---------------	-----------------------	-------------------	--------------------	--

--- FINAL DRAWING SIGN OFF ---
PRODUCT TO BE BUILT AND INSTALLED AS SHOWN:
APPROVED BY: _____
DATE: _____