

CONSTRUCTION TO BE DONE BY FACILITY:

- 64" WIDE x 88" HIGH MIN DOOR OPENING WITH 165" MIN SWING CLEARANCE
- ALL APPROVALS, PERMITS, AND AGENCY SUBMITTALS
- WET ENVIRONMENT, DESIGN ROOM ACCORDINGLY
- ROOM MUST REMAIN ABOVE FREEZING AT ALL TIMES OR WARRANTY IS VOIDED
- NEED FORKLIFT WITH FORKS 7.3/4" WIDE (MAX) x 6FT LONG (MINIMUM)
- FLOOR UNDER TREADMILL BE FLAT & LEVEL WITHIN .5" PER 12FT

PLUMBING TO BE DONE BY FACILITY:

- .4" FLOOR DRAIN NEAR TREADMILL CORNER AND WATER STORAGE TANK
- ADDITION DRAINS MAY BE ADDED TO HANDLE RAPIDLY DUMPED WATER
- COLD WATER SUPPLY WITH HOSE BIB, FOR FILLING WATER STORAGE TANK
- HOT WATER WITH HOSE BIB FOR MAKEUP, TREADMILL & CARTRIDGE CLEANING

FACILITY LAYOUT:

36' RECOMMENDED OVERALL TO ENTER & EXIT HORSES FROM TREADMILL (24' MINIMUM WITH BARN DOORS AS SHOWN) 12' TANK

ELECTRICAL TO BE DONE BY FACILITY:

- 230V | 1PH | 60HZ | 50AMP | 3 WIRE ELECTRICAL SUPPLY AND MOUNT DISCONNECT
- CONNECT INCOMING POWER TO CONTROL PANEL PER NEC CODE
- EQUIPMENT WILL RUN BELOW 230VAC, BUT SHORTENS LIFE EXPECTANCY AND VOIDS WARRANTY (AN AQUABOOST TRANSFORMER P/N0789490 RAISES 20VAC)
- HUDSON SUPPLIED:
- CUSTOM DESIGNED LAYOUT DRAWING WITH THE PURCHASE OF PRODUCT
- INSTALLATION OF PURCHASED ITEMS AS PER FINAL SIGNED DRAWING
- ON SITE IN-SERVICE TRAINING PROVIDED AFTER INSTALL
- *ASK SAW* WATER CARE SERVICE & AFTER HOURS SERVICE SUPPORT
- PROPOSED PLUMBING PATH FOR GRAVITY DRAINING OF UNITS

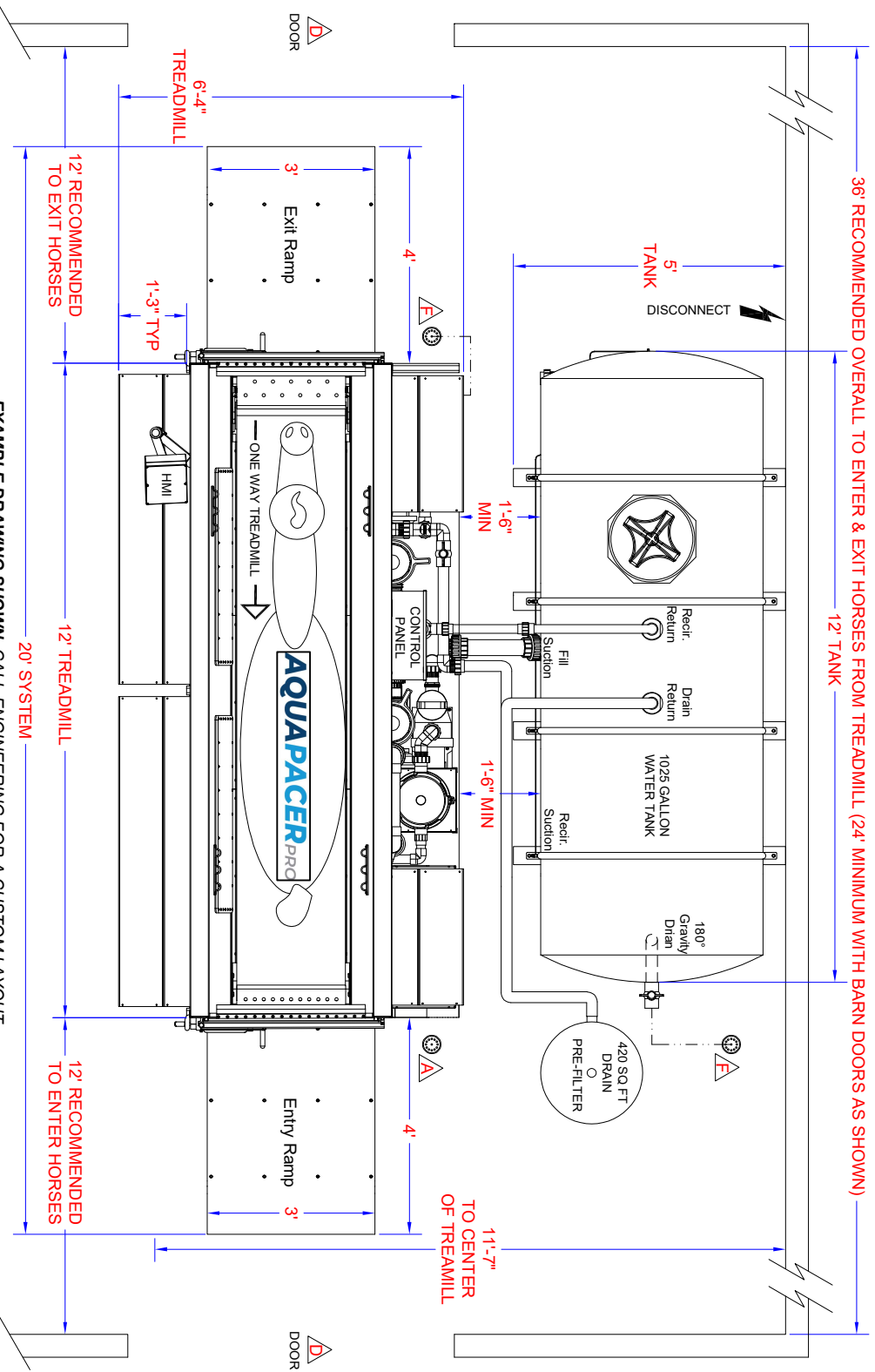

--- EXAMPLE DRAWING SHOWN. CALL ENGINEERING FOR A CUSTOM LAYOUT ---

PURCHASED SYSTEM:

- 0790657-C
- AQUAPACER
- 1025 GALLON TANK w/RECIRC.
- ENTRY RAMPS

PURCHASED OPTION:

- 0790481
- 420 SQ FT DRAIN PREFILTER

ELEVATION VIEW:

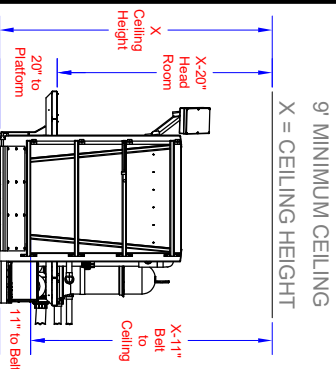

NOTE: CHECK HEAD CLEARANCES FOR HORSES AND HUMANS

WEIGHTS:

- TREADMILL EMPTY 4,500 LBS
- TREADMILL w/43" WATER 13,000 LBS
- 1025 GALLON TANK EMPTY 530 LBS
- 1025 GALLON TANK w/WATER 8,866 LBS
- FLOOR LOAD:**
- TREADMILL w/43" WATER 217 LBS PER SQ. FT.
- 1025 GALLON TANK w/WATER 246 LBS PER SQ. FT.

--- FINAL DRAWING SIGN OFF ---
PRODUCT TO BE BUILT AND INSTALLED AS SHOWN:

APPROVED BY: _____
DATE: _____



100 WOHLETT ST | ANGOLA, IN 46703
HOME: 1-800-939-5374 | ENG EXT: 222

DRAWN BY:	SALESMAN:	REV. DATE:	DRAWING #:	FACILITY NAME:
HJS	XXXXX XXXXX	4-2-24	XX-XXXX	AQUAPACER PRO w/RAMPS, 1025G TANK & PRE-FILTER (SAMPLE LAYOUT)